

MINIMUM CROSSBAR SPREAD 24" (61CM)

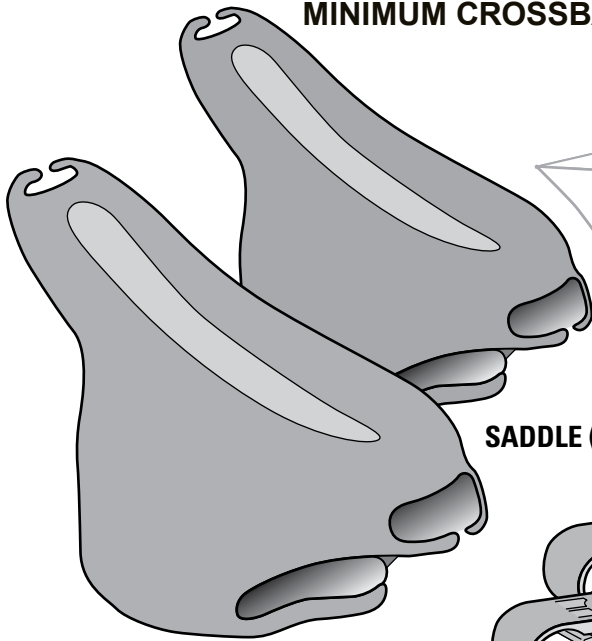

SADDLE (2X)

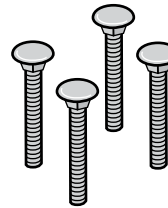
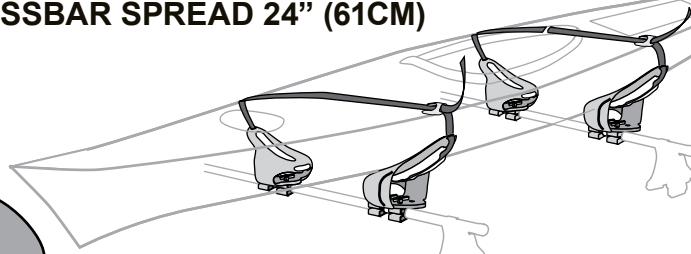

CARRIAGE BOLT (4X)

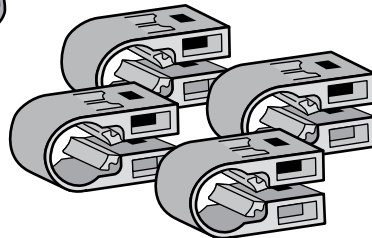

SNAP AROUND (4X)

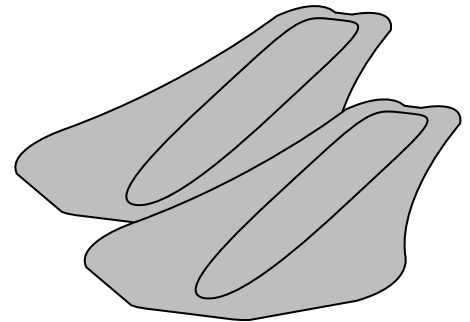

FELT PADS (2X)

BUCKLE STRAP (1X)

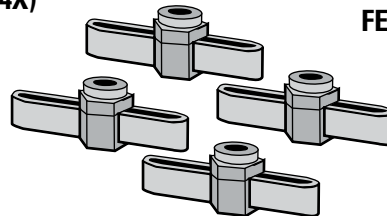
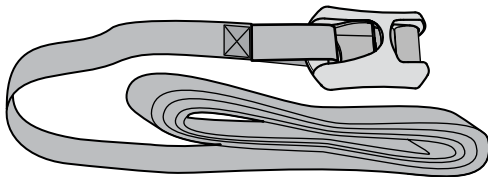

HEX KEY (4X)

## BOW STERN TIE DOWN

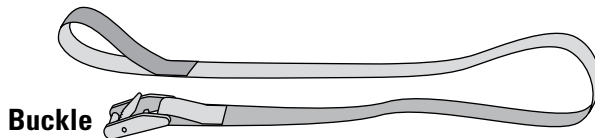

Buckle

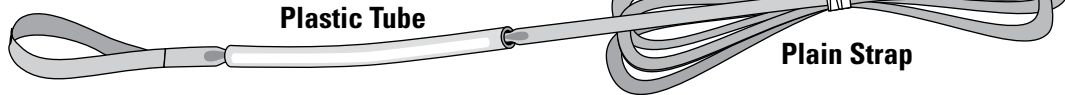

Plastic Tube

Plain Strap

Steel Hook



### IMPORTANT WARNING

IT IS CRITICAL THAT ALL YAKIMA RACKS AND ACCESSORIES BE PROPERLY AND SECURELY ATTACHED TO YOUR VEHICLE. IMPROPER ATTACHMENT COULD RESULT IN AN AUTOMOBILE ACCIDENT, AND COULD CAUSE SERIOUS BODILY INJURY OR DEATH TO YOU OR TO OTHERS. YOU ARE RESPONSIBLE FOR SECURING THE RACKS AND ACCESSORIES TO YOUR CAR, CHECKING THE ATTACHMENTS PRIOR TO USE, AND PERIODICALLY INSPECTING THE PRODUCTS FOR ADJUSTMENT, WEAR, AND DAMAGE. THEREFORE, YOU MUST READ AND UNDERSTAND ALL OF THE INSTRUCTIONS AND CAUTIONS SUPPLIED WITH YOUR YAKIMA PRODUCT PRIOR TO INSTALLATION OR USE. IF YOU DO NOT UNDERSTAND ALL OF THE INSTRUCTIONS AND CAUTIONS, OR IF YOU HAVE NO MECHANICAL EXPERIENCE AND ARE NOT THOROUGHLY FAMILIAR WITH THE INSTALLATION PROCEDURES, YOU SHOULD HAVE THE PRODUCT INSTALLED BY A PROFESSIONAL INSTALLER SUCH AS A QUALIFIED GARAGE OR AUTO BODY SHOP.

# DO YOU HAVE - SQUARE - ROUND - OR FACTORY CROSSBARS?

**1 SQUARE**

**SQUARE BARS ONLY**

Loosen the tabs in the SnapArounds by bending them repeatedly.

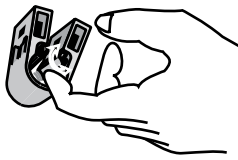

Remove the tabs with scissors or pliers.

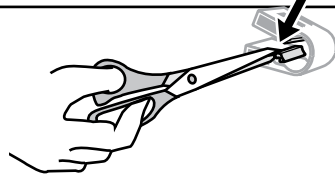

**1 ROUND**

*(SQUARE continued)*

Attach four SnapArounds to the front crossbar (2 per saddle).

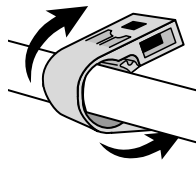
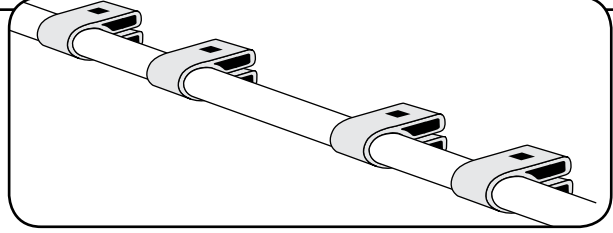
**1 FACTORY BARS**

Attach four MightyMounts to the front crossbar (2 per saddle).

*If your MightyMounts require bar caps, install them now.*

**UNIVERSAL MIGHTYMOUNT #03590**

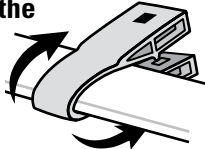
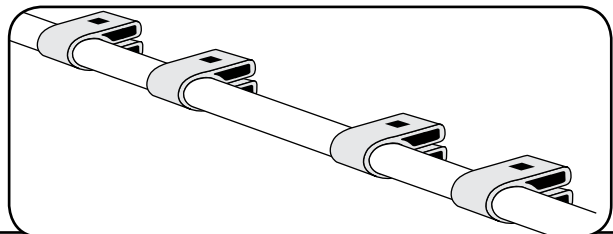

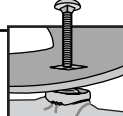
Follow the Universal MightyMount instructions and refer to this instruction for correct installation.

**2 APPLY OPTIONAL FELT PADS.**

Remove cutout.



Remove backing.



Apply to Mako.



Repeat for each Mako.



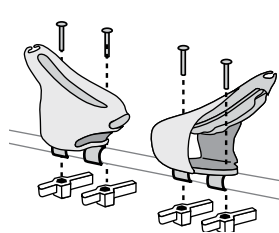
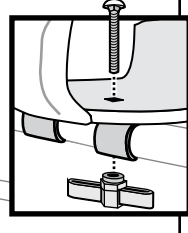

**3 ROUND / SQUARE:**

- Push bolts through saddles and into SnapArounds.
- Attach hex keys and tighten.

**3 FACTORY BARS:**

- Push bolts through the saddles and into the MightyMounts.
- Tighten bolts with MightyMount wrench.

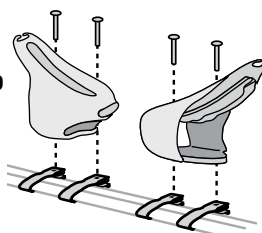
**4 INSTALL SECOND SET OF SADDLES OR ROLLERS.**

**SADDLES:**

- Repeat installation for second set of saddles,

**YAKIMA HULLYROLLERS:**

- Follow installation instructions in HullyRollers kit.

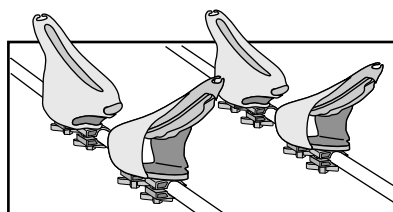
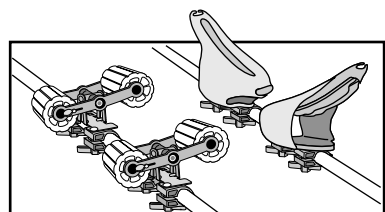
## 5 LOAD YOUR CRAFT

- Place craft in saddles.
- Adjust position of saddles as needed.
- Completely tighten all bar attachments.

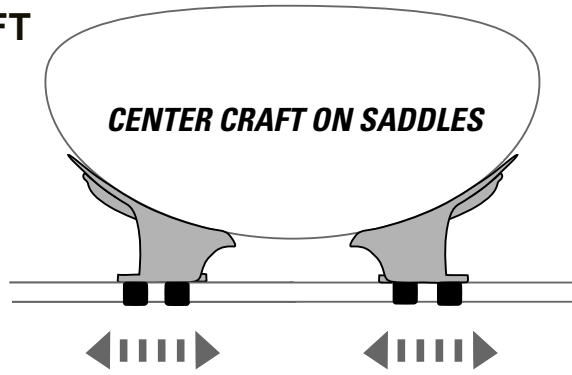

*Loosen attachment hardware completely before sliding saddles along crossbars. Tighten all bar attachments.*

## 6 INSTALL STRAP.

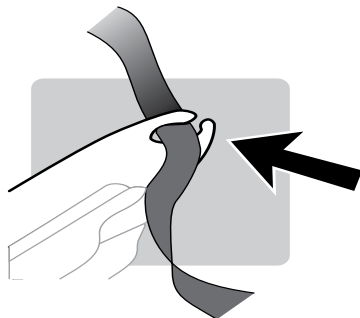

- Insert buckle strap into notch at top of saddle.

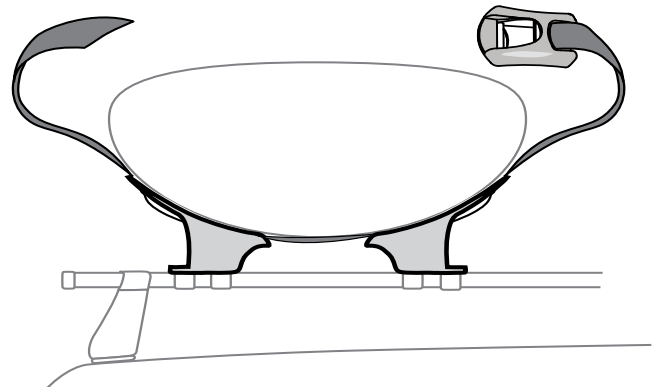

- Loop strap through saddles.

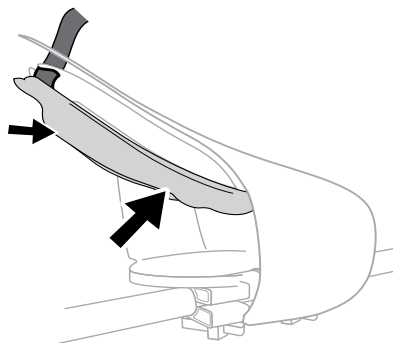

- Place straps in groove on underside of each pad.

## 7 TIGHTEN STRAPS.

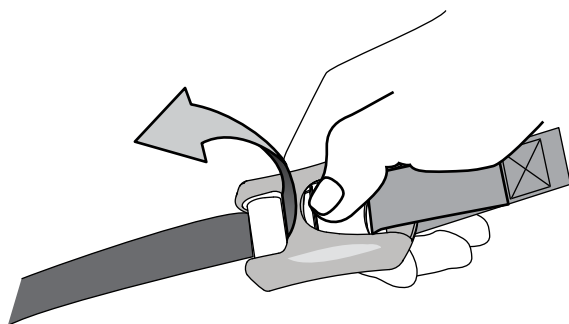

- Insert end of strap into buckle as shown.

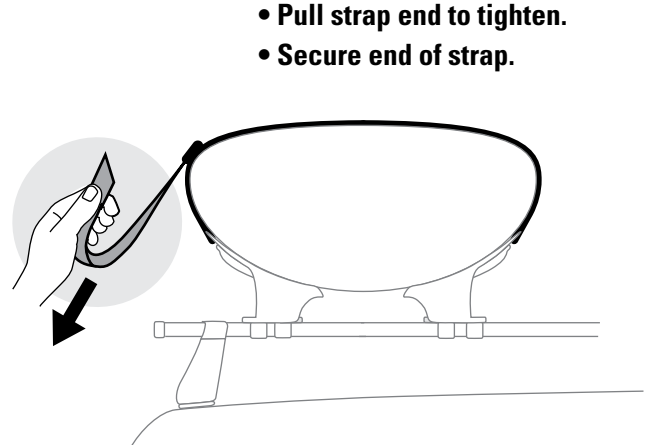

- Pull strap end to tighten.
- Secure end of strap.

**8** Attach buckle strap to boat.

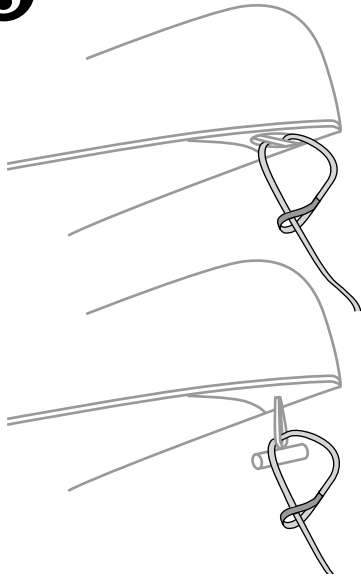

Attach strap to grab handle or rescue bar and pull tight.

**9** Attach hook to plain strap loop.

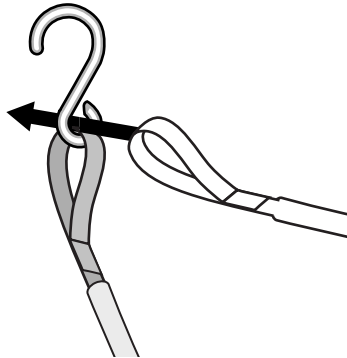

**10** Hook the strap to a metal surface on the bumper, tow loop, or frame hole using hook.

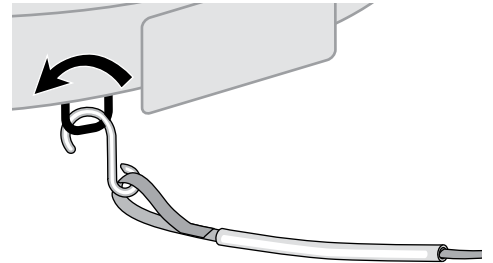

**11** Slide plastic tube to protect vehicle at contact point.

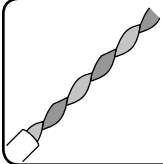

**NOTE:** Twisting the strap will help reduce wind vibration.

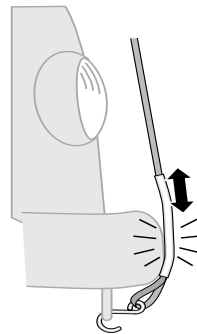

**13** Adjust strap tension by pulling plain end.

- Apply even pressure to front and rear straps.
- Bind up and tie off any excess strap.

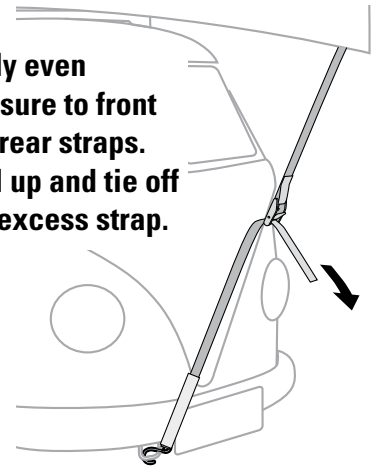

**12** Insert end of plain strap into buckle.

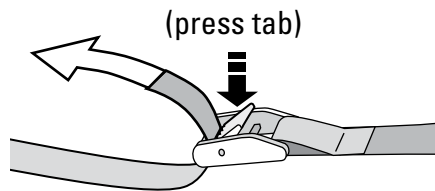

*Failure to secure front and rear of long loads to ends of vehicle can result in property damage, personal injury, or death.*



**BEFORE DRIVING AWAY**

- Test movement by rocking boat.
- Tighten again if loose.
- **READ ALL CAUTIONS AND LIMITS ON NEXT PAGE.**



*Check straps periodically during travel and tighten if necessary. Replace any straps that are worn or frayed before using (see your Yakima dealer).*

**SEE YOUR ACCESSORY INSTRUCTIONS FOR IMPORTANT WARNINGS**

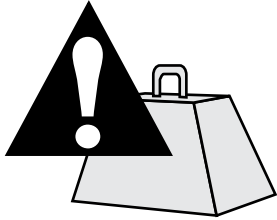

## **WEIGHT LIMITS**

Follow the YAKIMA Fit List for your rack's weight limit.

**DO NOT EXCEED THE WEIGHT LIMIT  
OF YOUR VEHICLE'S RACKS.**

Maximum weight is 165 lbs. (75 kg) unless otherwise noted.

**IF YOU REMOVE YOUR CARRIER, FOLLOW INSTRUCTIONS TO INSTALL AGAIN.**

Follow safety checks in accessory instructions before every installation.

### **REAR HATCH**

Some longer loads may prevent the rear hatch from fully opening.

**ALWAYS USE CAUTION WHEN  
OPENING YOUR HATCH.**

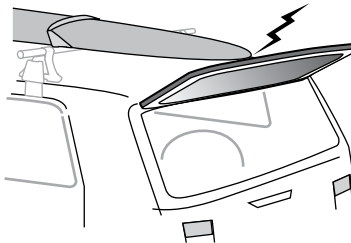

### **ANTENNA**

Antenna on the roof may need to be removed to prevent interference with long loads.

**WARNING: BE SURE ALL HARDWARE IS SECURED ACCORDING TO INSTRUCTIONS. ATTACHMENT HARDWARE CAN LOOSEN OVER TIME. CHECK BEFORE EACH USE, AND TIGHTEN IF NECESSARY.**

**MAINTENANCE:** Use non-water soluble lubricant on screws. Use a soft cloth with water and mild detergent to clean plastic parts.

---

**REMOVE ACCESSORY BEFORE ENTERING AN  
AUTOMATIC CAR WASH.**

**TECHNICAL ASSISTANCE  
OR REPLACEMENT PARTS**  
Contact your dealer or call  
(888)925-4621

Monday through Friday,  
7:00 AM to 5:00 PM, PST



This product is covered by YAKIMA's  
"Love It Till You Leave It" Limited Lifetime Warranty  
To obtain a copy of this warranty, go online to  
[www.yakima.com](http://www.yakima.com) or email us at  
[yakwarranty@yakima.com](mailto:yakwarranty@yakima.com) or call (888) 925-4621

**KEEP THESE INSTRUCTIONS!**

# YAKIMA MAKO SADDLES

FR

DISTANCE MINIMALE ENTRE LES BARRES  
TRANSVERSALES : 61 CM (24 PO)

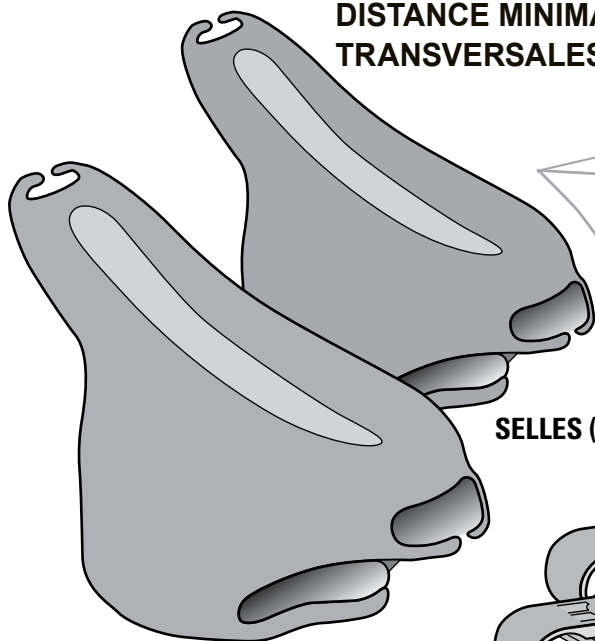

SELLES (X 2)

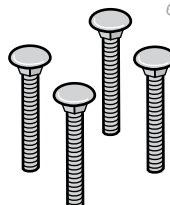
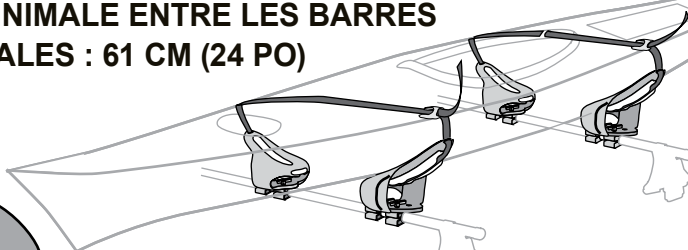

BOULONS À TÊTE  
BOMBÉE (X 4)

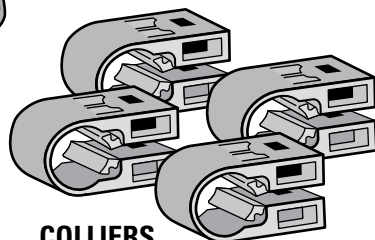

COLLIERS  
SNAPAROUND (X 4)

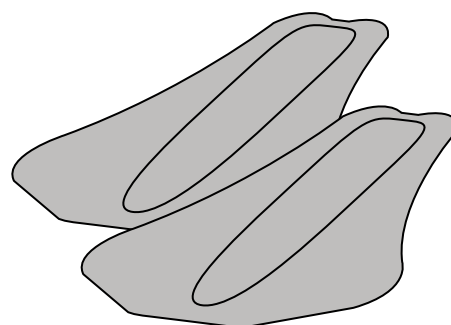

GARNITURES  
EN FEUTRE (X 2)

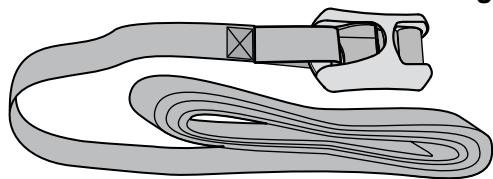

SANGLE AVEC BOUCLE (X 1)

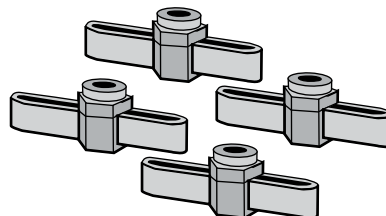

ÉCROUS À AILETTES (X 4)

## ATTACHE DE PROUE/DE POUPE

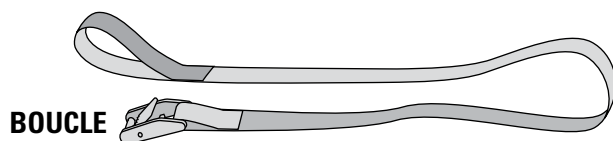

BOUCLE

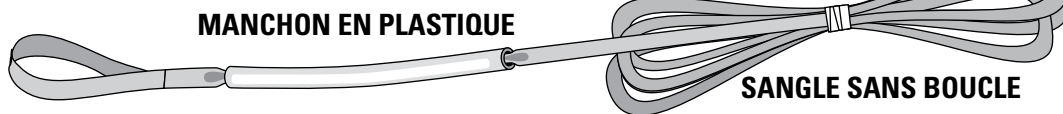

MANCHON EN PLASTIQUE

SANGLE SANS BOUCLE

CROCHET EN  
ACIER



## AVERTISSEMENT IMPORTANT

IL EST IMPÉRATIF QUE LES PORTE-BAGAGES ET LES ACCESSOIRES YAKIMA SOIENT CORRECTEMENT ET SOLIDEMENT FIXÉS AU VÉHICULE. UN MONTAGE MAL RÉALISÉ POURRAIT PROVOQUER UN ACCIDENT D'AUTOMOBILE, QUI POURRAIT ENTRAÎNER DES BLESSURES GRAVES OU MÊME LA MORT, À VOUS OU À D'AUTRES PERSONNES. VOUS ÊTES RESPONSABLE DE L'INSTALLATION DU PORTE-BAGAGES ET DES ACCESSOIRES SUR VOTRE VÉHICULE, D'EN VÉRIFIER LA SOLIDITÉ AVANT DE PRENDRE LA ROUTE ET DE LES INSPECTER RÉGULIÈREMENT POUR EN CONTRÔLER L'ÉTAT, L'AJUSTEMENT ET L'USURE. VOUS DEVEZ DONC LIRE ATTENTIVEMENT TOUTES LES INSTRUCTIONS ET TOUS LES AVERTISSEMENTS ACCOMPAGNANT VOTRE PRODUIT YAKIMA AVANT DE L'INSTALLER ET DE L'UTILISER. SI VOUS NE COMPRENEZ PAS TOUTES LES INSTRUCTIONS ET TOUS LES AVERTISSEMENTS, OU SI VOUS N'AVEZ PAS DE COMPÉTENCES EN MÉCANIQUE ET NE COMPRENEZ PAS PARFAITEMENT LA MÉTHODE DE MONTAGE, VOUS DEVRIEZ FAIRE INSTALLER LE PRODUIT PAR UN PROFESSIONNEL, COMME UN MÉCANICIEN OU UN CARROSSIER COMPÉTENT.

## LES BARRES TRANSVERSALES SONT-ELLES CARRÉES, RONDES OU BARRES D'ORIGINE ?

**1 CARRÉES**

**BARRES CARRÉES SEULEMENT**

Assouplir les cales des colliers SnapAround en les pliant plusieurs fois.

Enlever les cales avec des ciseaux ou des pinces.

**1 RONDES**

(suite des CARRÉES)

Enfiler 4 colliers SnapAround (2 par selle) sur la barre avant.

**1 BARRES D'ORIGINE**

Enfiler 4 colliers MightyMount (2 par selle) sur la barre avant.

S'il faut des cales pour les colliers MightyMount, les poser maintenant.

**COLLIERS MIGHTYMOUNT UNIVERSELS N°03590**

Suivre les instructions accompagnant les colliers MightyMount universels et consulter les présentes instructions quant à leur pose.

**2 POSER LES GARNITURES EN FEUTRE OPTIONNELLES.**

Enlever la découpe.

Enlever l'endos.

Coller sur la selle.

Recommencer pour chaque selle.

**3 RONDES / CARRÉES:**

- Enfiler les boulons à travers la selle, puis dans les colliers SnapAround.
- Mettre en place les écrous à ailettes et les serrer.

**3 BARRES D'ORIGINE:**

- Enfiler les boulons à travers la selle, puis dans les colliers MightyMount.
- Serrer avec la clé.

**4 POSER LA DEUXIÈME PAIRE DE SELLES OU DE ROULEAUX.**

**SELLES :**

- Procéder de la même manière pour poser la deuxième paire de selles.

**HULLYROLLER DE YAKIMA :**

- Suivre les instructions qui accompagnent les rouleaux HullyRoller.

## 5 CHARGER L'EMBARCATION

- Déposer l'embarcation sur les selles.
- Régler la position des selles selon la forme de la coque.
- Terminer le serrage des colliers sur les barres.

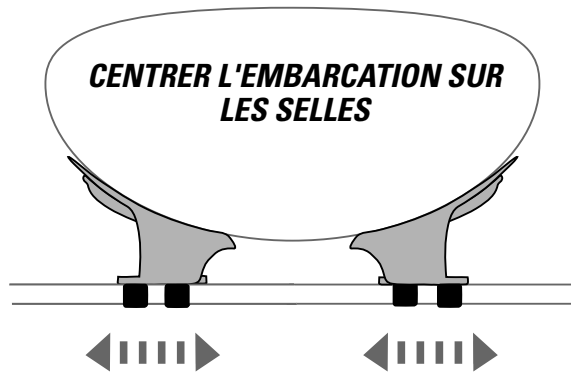

*Desserrer complètement les boulons pour faire coulisser les selles sur les barres.  
Bien resserrer les boulons des colliers sur les barres.*

## 6 POSER LES SANGLES.

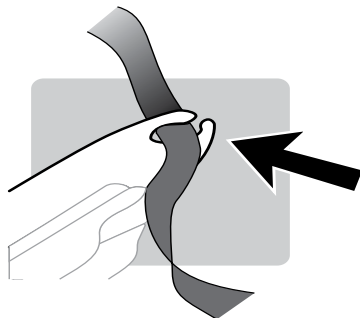

- Enfiler la sangle avec boucle dans la coche au sommet de la selle.

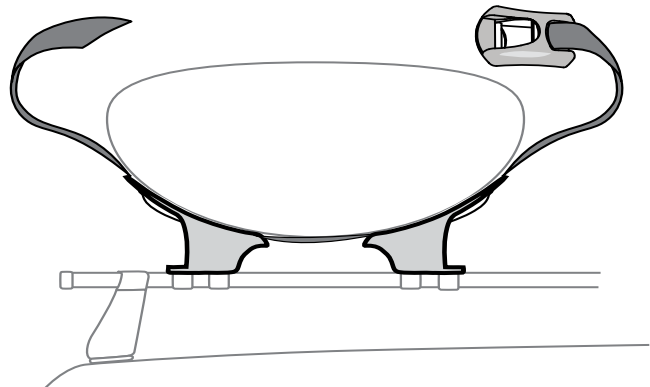

- Faire passer la sangle à travers les selles.

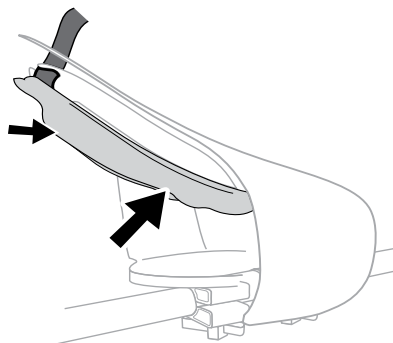

- Placer la sangle dans la rainure se trouvant sous chaque selle.

## 7 SERRER LES SANGLES.

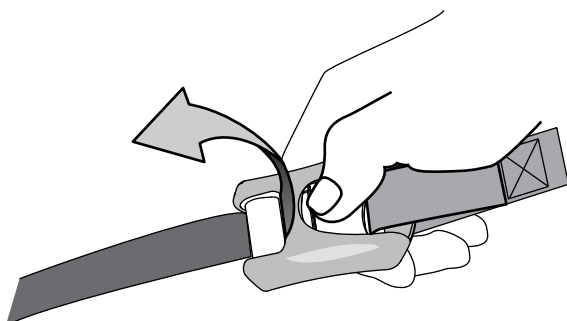

- Enfiler le bout de la sangle dans la boucle tel qu'illustré.

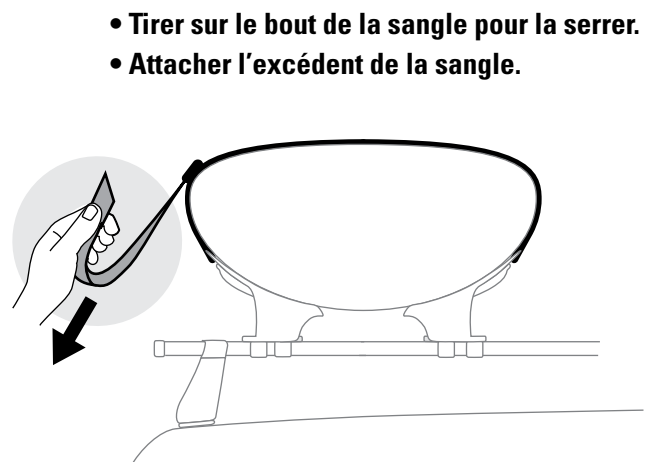

- Tirer sur le bout de la sangle pour la serrer.
- Attacher l'excédent de la sangle.



**8** Attacher la sangle avec boucle à l'embarcation.

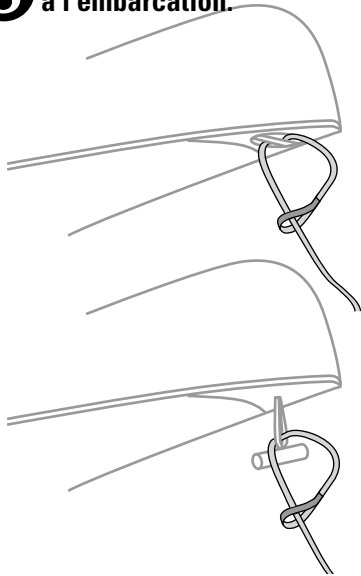

Fixer la sangle à la poignée ou à la barre de transport et bien serrer.

**9** Fixer le crochet dans l'anneau de la sangle sans boucle.

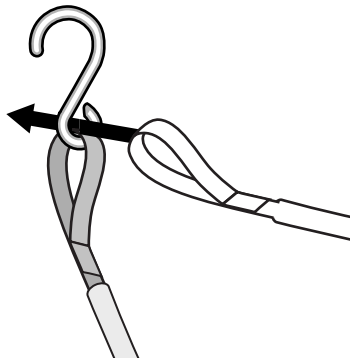

**10** Accrocher la sangle à un rebord métallique du pare-chocs, à un anneau de remorquage ou dans un trou du châssis.

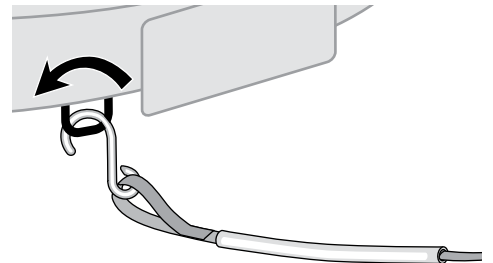

**11** Faire coulisser le manchon en plastique pour protéger le véhicule au point de contact.

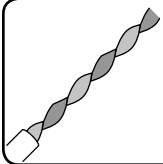

**REMARQUE :** si l'on donne plusieurs tours à la sangle elle vibrera moins dans le vent.

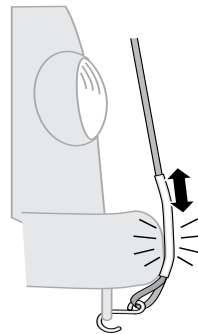

**12** Enfiler le bout de la sangle sans boucle dans la boucle.

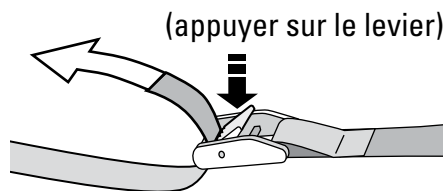

**13** Régler la tension de la sangle en tirant sur le bout libre.

- Tendre également les sangles avant et arrière.
- Enrouler et attacher l'excédent des sangles.

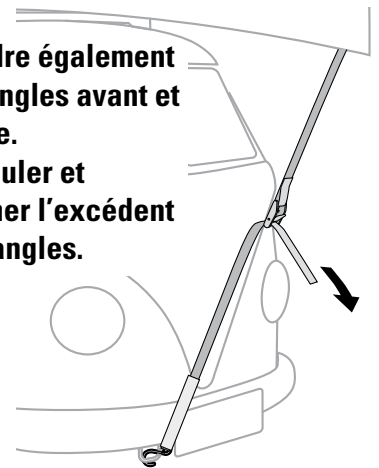

**Toujours attacher le bout des charges longues à l'avant et à l'arrière du véhicule, sous peine de risquer de provoquer des dommages, des blessures ou même la mort.**

## AVANT DE PRENDRE LA ROUTE



- Vérifier la solidité du montage en balançant l'embarcation.
- Serrer les sangles ou les boulons un peu plus s'il y a du jeu.
- **LIRE TOUS LES AVERTISSEMENTS ET RESPECTER LES LIMITES FIGURANT À LA PAGE SUIVANTE.**



**Vérifier les sangles régulièrement durant le trajet et les serrer au besoin. Si une sangle est usée ou effilochée, la remplacer (consulter le dépositaire Yakima).**

**LIRE LES AVERTISSEMENTS IMPORTANTS FIGURANT DANS LES INSTRUCTIONS ACCOMPAGNANT L'ACCESSOIRE**

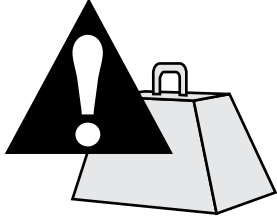

## LIMITE DE CHARGEMENT

Consulter la liste de compatibilité YAKIMA ("Fit list") pour connaître la limite de chargement. **NE PAS DÉPASSER LA LIMITE DE CHARGEMENT FIXÉE POUR LE PORTE-BAGAGES D'ORIGINE.**

La charge maximale est de 75 kg (165 lb) à moins d'indication contraire.

**SI L'ON ENLÈVE LE PORTE-EMBARCATION, SUIVRE LES INSTRUCTIONS POUR LE REMETTRE EN PLACE.**

Respecter les consignes de sécurité figurant dans les instructions avant chaque montage.

### HAYON

Certaines charges particulièrement longues pourraient empêcher d'ouvrir complètement le hayon.

**TOUJOURS OUVRIR LE HAYON AVEC PRUDENCE.**

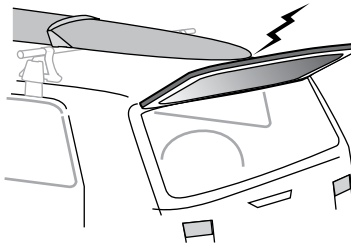

### ANTENNE

Il faudra peut-être enlever l'antenne du toit si elle gêne les charges longues.

**ATTENTION : S'ASSURER QUE LE MONTAGE EST SOLIDE ET CONFORME AUX INSTRUCTIONS. LES DISPOSITIFS DE FIXATION PEUVENT SE DESSERRER À LA LONGUE. LES INSPECTER AVANT CHAQUE UTILISATION ET LES RESSERRER AU BESOIN.**

**ENTRETIEN :** lubrifier les boulons avec un lubrifiant non soluble à l'eau. Nettoyer les pièces en plastique avec un chiffon, de l'eau et un savon doux.

**ENLEVER L'ACCESSOIRE AVANT DE PASSER DANS UN LAVE-AUTO AUTOMATIQUE.**

**RENSEIGNEMENTS TECHNIQUES OU PIÈCES DE RECHANGE,** prière de contacter votre dépositaire ou appeler au (888) 925-4621, du lundi au vendredi entre 7h et 17h, heure du Pacifique.



Ce produit est couvert par la garantie limitée « Tant que durera notre histoire d'amour » YAKIMA. Pour se procurer une copie de cette garantie, aller en ligne à [www.yakima.com](http://www.yakima.com) ou nous envoyer un courriel à [yakwarranty@yakima.com](mailto:yakwarranty@yakima.com) ou appeler au (888) 925-4621.

**CONSERVER CES INSTRUCTIONS!**

# YAKIMA MAKO SADDLES

ES

SEPARACIÓN MÍNIMA ENTRE LAS BARRAS  
TRANSVERSALES 24" (61 CM)

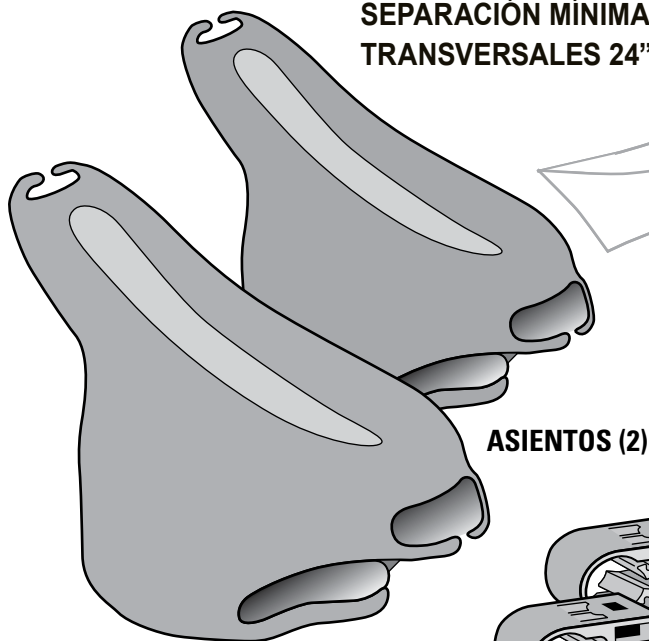

ASIENTOS (2)

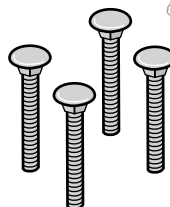
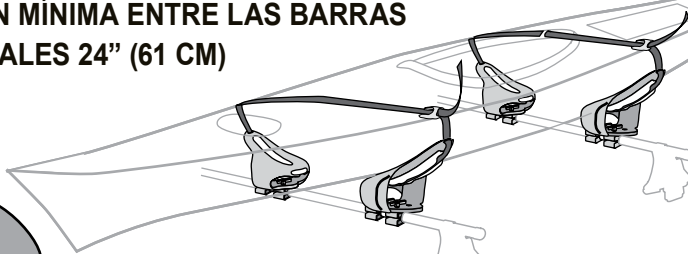

BULONES PERNO (4)

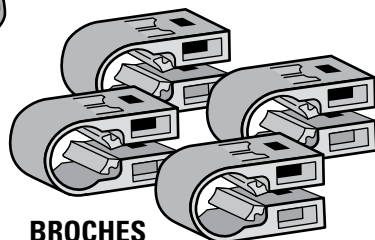

BROCHES  
SNAPAROUND (4)

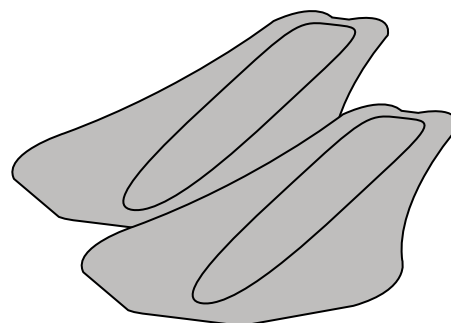

ALMOHADILLAS  
DE FIELTRO (2X)

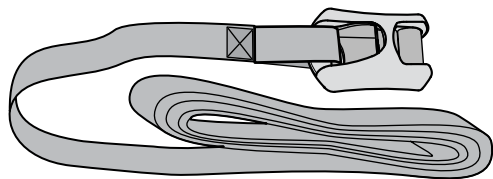

CORREA CON HEBILLA (1)

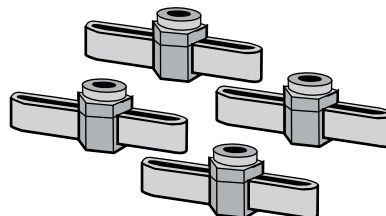

TUERCAS MARIPOSA (4)

## AMARRE PARA PROA Y POPA

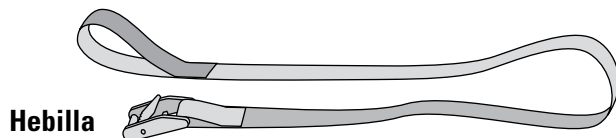

Hebilla

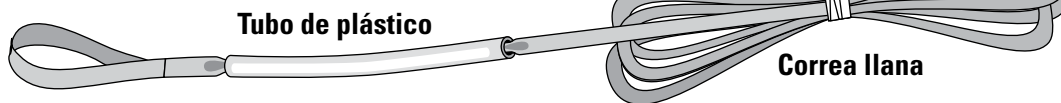

Tubo de plástico

Correa llana

Gancho  
de acero



## AVISO IMPORTANTE!

ES FUNDAMENTAL QUE TODAS LAS PARRILLAS Y ACCESORIOS YAKIMA ESTÉN BIEN COLOCADOS Y ASEGURADOS AL VEHÍCULO. UNA INSTALACIÓN DEFICIENTE PODRÍA RESULTAR EN ACCIDENTE AUTOMOVILÍSTICO Y PROVOCAR HERIDAS GRAVES O MUERTE A USTED O A TERCEROS. USTED ES RESPONSABLE DE ASEGURAR LAS PARRILLAS Y ACCESORIOS AL VEHÍCULO, VERIFICANDO UNIONES Y AMARRES ANTES DE USAR E INSPECCIONANDO EL AJUSTE DE LOS PRODUCTOS, SU DESGASTE Y POSIBLES DAÑOS. POR ELLO DEBE LEER Y COMPRENDER TODAS LAS INSTRUCCIONES Y ADVERTENCIAS QUE VIENEN CON LOS PRODUCTOS YAKIMA ANTES DE INSTALARLOS O USARLOS. SI NO ENTIENDE TODAS LAS INSTRUCCIONES Y ADVERTENCIAS, O NO TIENE EXPERIENCIA EN MECÁNICA O NO ESTÁ FAMILIARIZADO CON LOS PROCEDIMIENTOS DE INSTALACIÓN, HAGA INSTALAR EL PRODUCTO POR UN PROFESIONAL EN UN GARAGE CONOCIDO O EN UN TALLER DE CARROCERÍA.

¿TIENE SU VEHÍCULO BARRAS CUADRADAS, REDONDAS O BARRAS DE FÁBRICA?

**1 CUADRADAS**

**BARRAS CUADRADAS SOLAMENTE**

Desajuste las lengüetas en los broches SnapAround, doblándolas repetidas veces.

Retire las lengüetas con tijeras o alicates.



**1 REDONDAS**

*(BARRAS CUADRADAS continúa)*

Sujete 4 broches SnapAround a la barra transversal frontal (2 por asiento).

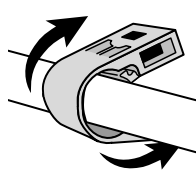
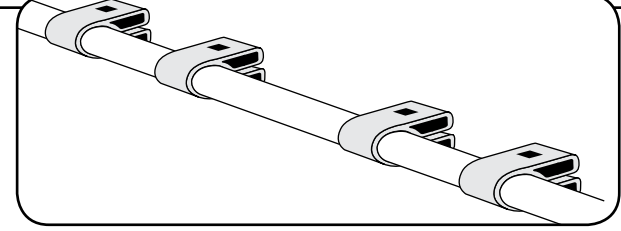

**1 BARRAS DE FÁBRICA**

Sujete 4 broches MightyMount a la barra transversal frontal (2 por asiento).

*Si sus broches MightyMount necesitan tapones para barras, instálelos ahora.*

**BROCHES UNIVERSALES MIGHTYMOUNT (#03590)**

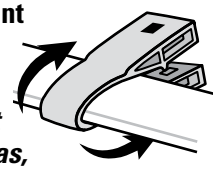
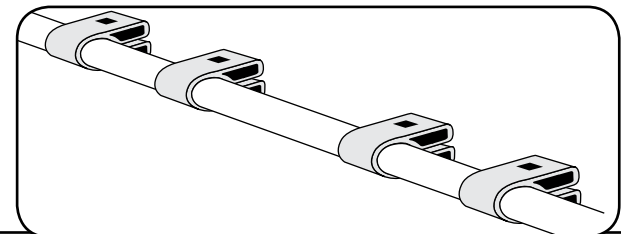
Siga las instrucciones de los broches universales MightyMount y remítase a estas indicaciones para obtener una instalación correcta.

**2 INSTALE LAS ALMOHADILLAS DE FIELTRO OPCIONALES.**

Retire la parte recortable.

Retire la película protectora.

Colóquela en el Mako.

Repita la operación para cada Mako.





**3 REDONDAS / CUADRADAS:**

- Introduzca los bulones perno por los asientos y luego páselos a través de los broches SnapAround.
- Ajuste con las tuercas mariposa.

**3 BARRAS DE FÁBRICA:**

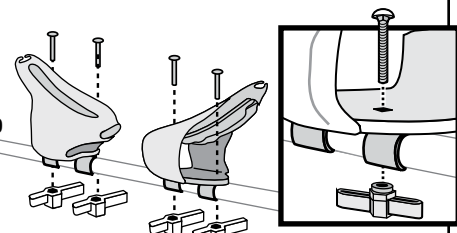
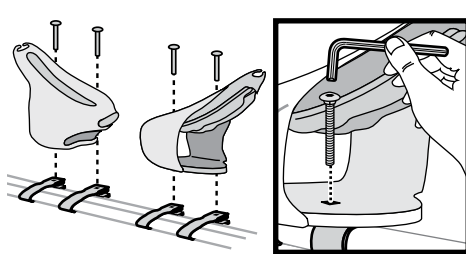
- Introduzca los bulones perno por los asientos y luego páselos a través de los broches MightyMount.
- Ajuste con la llave.

**4 INSTALE UN SEGUNDO PAR DE ASIENTOS O UN PAR DE RODILLOS HULLYROLLERS**

**ASIENTOS:**

- Repita la misma instalación para el segundo par de asientos.

**HULLYROLLERS DE YAKIMA:**

- Siga las instrucciones de instalación indicadas en el kit HullyRollers.





## 5 CARGUE SU EQUIPO

- Coloque su equipo sobre los asientos.
- Ajuste la posición de los asientos como sea necesario.
- Ajuste completamente todas las sujeciones de la barra.

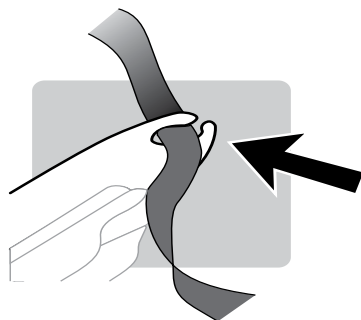

**¡Desajuste completamente el herraje de sujeción antes de deslizar los asientos por las barras transversales!**  
**¡Ajuste todas las sujeciones de la barra!**

## 6 INSTALE LAS CORREAS.



- Inserte la correa con hebilla en la ranura, por la parte de arriba del asiento.

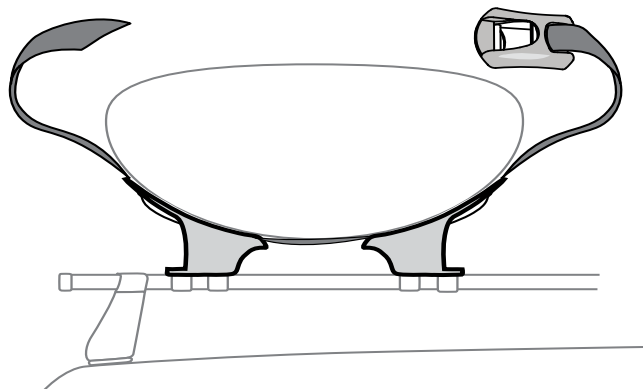

- Pase la correa por los asientos.

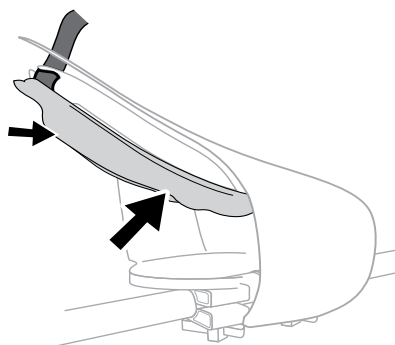

- Pase la correa por la ranura de cada almohadilla.

## 7 AJUSTE LAS CORREAS.

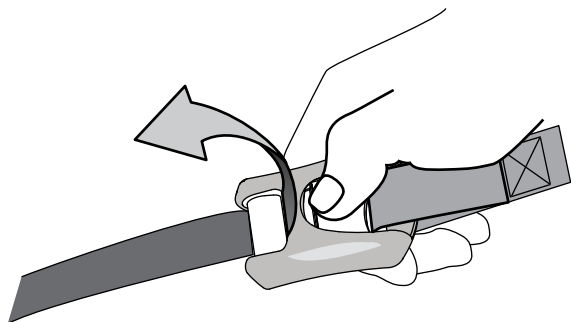

- Inserte el extremo de la correa en la hebilla, como se muestra.

- Tire del extremo de la correa para apretar.
- Asegure el extremo de la correa.

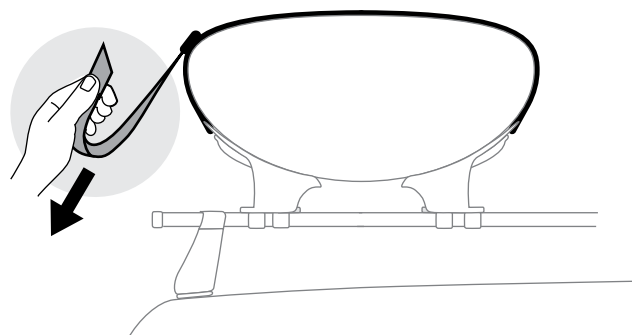

**8** Sujete la correa con hebilla al bote.

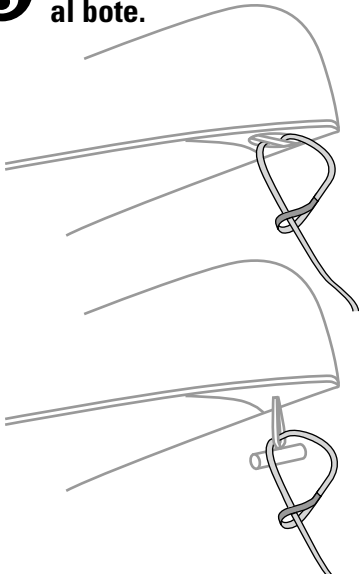

Sujete la correa al asa o a la barra de rescate y tire bien de ella.

**9** Pase el gancho por el bucle de la correa llana.

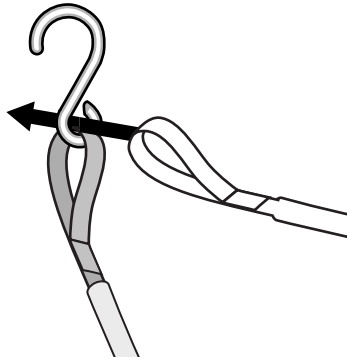

**10** Enganche la correa con el gancho de acero a una superficie metálica en el parachoques, bucle de remolque o agujero de la carrocería.

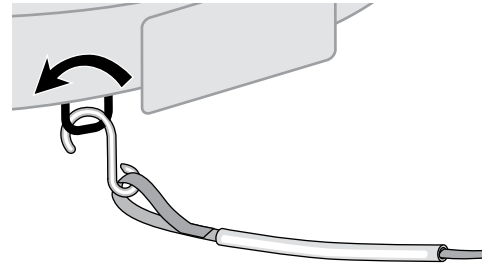

**11** Deslice el tubo de plástico para proteger el vehículo en los puntos de contacto.

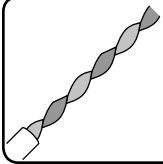

**NOTA:** Torcer la correa ayudará a reducir la vibración que causa el viento.

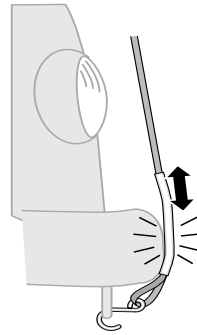

**12** Inserte el extremo de la correa llana en la hebilla.

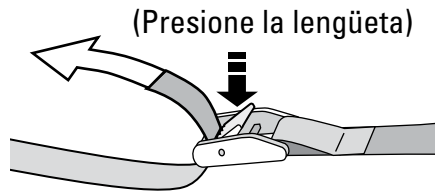

**13** Ajuste la tensión de la correa jalando el extremo plano.

- Aplique presión uniforme a las correas delanteras y traseras.
- Fije y ate cualquier exceso de la correa.

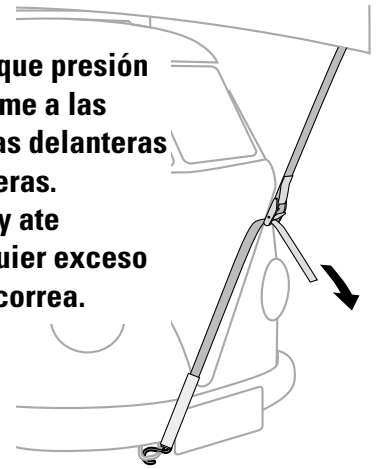

**No asegurar la parte delantera y trasera de las cargas a los extremos del vehículo, puede ocasionar daños a la propiedad, lesiones o incluso la muerte.**

## ANTES DE SALIR DE VIAJE



- Revise el movimiento, meciendo el bote.
- Ajuste nuevamente el herraje si está flojo.
- LEA EN LA PÁGINA SIGUIENTE TODAS LAS PRECAUCIONES NECESARIAS Y LA INFORMACIÓN RELACIONADA A LOS LÍMITES DE PESO.



**Revise las correas periódicamente durante el viaje y ajústelas si es necesario. Reemplace toda correa gastada o raída antes de usarla (consulte con su concesionario Yakima).**

**REMÍTASE A LAS INSTRUCCIONES REFERENTES A LOS ACCESORIOS PARA INFORMARSE SOBRE LAS ADVERTENCIAS IMPORTANTES.**

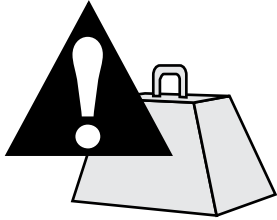

## LÍMITES DE PESO

Siga la guía de uso de YAKIMA para informarse sobre el límite de peso de los rieles.  
**NO EXCEDA EL LÍMITE DE PESO DE LOS RIELES DE SU VEHÍCULO.**

El peso máximo es de 165 libras (75 kg), a menos que se indique lo contrario.

**SI USTED RETIRA SU PORTAEQUIPAJES, SIGA NUEVAMENTE LAS INSTRUCCIONES PARA INSTALARLO.**

Antes de cada instalación, siga las revisiones de seguridad que se indican en las instrucciones de los accesorios.

### PUERTA TRASERA

Algunas cargas largas podrían impedir la apertura completa de la puerta trasera.

**SIEMPRE TOMA TODAS LAS PRECAUCIONES NECESARIAS AL ABRIR LA PUERTA TRASERA.**

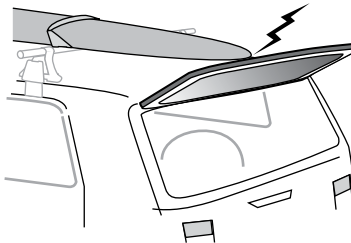

### ANTENA

Podría necesitar sacar la antena del techo, para evitar interferencia con las cargas largas.

**ADVERTENCIA: CERCÍOARSE DE QUE TODO EL HERRAJE ESTÉ ASEGURADO SEGÚN LAS INSTRUCCIONES INDICADAS. EL HERRAJE AJUSTADO PUEDE AFLOJARSE CON EL TIEMPO. VERIFIQUELO ANTES DE CADA USO Y AJÚSTELO SI ES NECESARIO.**

**MANTENIMIENTO:** Use lubricante no soluble en agua para los tornillos. Use un paño suave y humedecido con agua y detergente suave para limpiar las piezas de plástico.

**RETIRE LOS ACCESORIOS ANTES DE ENTRAR A UN ESTABLECIMIENTO PARA LAVADO AUTOMÁTICO DE VEHÍCULOS**

### ASISTENCIA TÉCNICA O PIEZAS DE REPUESTO

Comuníquese con su concesionario o llame al (888) 925-4621, de lunes a viernes, de 7.00 a 17.00 horas, hora estándar del Pacífico.



**GARANTÍA LIMITADA A VIDA “MIENTRAS DURE EL ROMANCE”**  
Este producto está cubierto por la garantía limitada a vida “mientras dure el romance” de Yakima. Para obtener una copia de esta garantía, visítenos en [www.yakima.com](http://www.yakima.com), envíenos un correo electrónico a [yakwarranty@yakima.com](mailto:yakwarranty@yakima.com) o llámenos al (888) 925-4621.

**CONSERVE ESTAS INSTRUCCIONES**